

Job Name: _____
 Type: _____
 Voltage: _____



CODES AND STANDARDS

UL 924 listed
 NFPA, NEC, and OSHA
 UL wet location listed
 NEMA 250 (NEMA 4x classification)
 IEC 61951-1 Life Testing
 (Nicad batteries IEC 529 (60529) IP66
 NSF Standard 2 "Splash Zone"

VOLTAGE INPUT

120/277 VAC dual voltage input with surge protection is standard on all models.

CONSTRUCTION

Housing constructed of impact-resistant Lexan® with corrosion resistant hardware. Housing color is gray. A one-piece, molded gasket, and unexposed metallic hardware prolong product life in highly corrosive areas. A hinged, removable cover allows for hands-free wiring.

ELECTRONICS

Charging system is microprocessor driven with software embedded diagnostic routine and precision temperature compensation. Surge protection, brownout, AC lockout, and low voltage disconnect features are standard.

BATTERY

The battery assemblies have been pre-qualified for use based on anticipated ambient temperatures. Battery assemblies consist of sealed, maintenance-free lead calcium, pure lead, or nickel cadmium batteries which supply a minimum of 90 minutes of emergency power at the lowest rated temperature of the model selected without de-rating the fixture.

ILLUMINATION

Two lamp heads internally mounted on the bottom of the unit for optimum path of egress illumination. Lamps are held in a molded swivel assembly and are fully adjustable. Each lamp head utilizes a PAR 36 sealed beam tungsten or halogen lamp. Unit is available with or without lamp heads installed.

INSTALLATION

The NFORCER is supplied with a wall mount bracket standard. A universal mounting kit for column, pole, or I-beam mounting is available as an accessory item.

WARRANTY

Three year full electronics warranty. One year full plus four year prorated lead calcium or pure lead battery warranty. Five year full plus five year prorated nickel cadmium battery warranty.

CATALOG NUMBER (Example: NF12100EPN-TTD)

FAMILY	BATTERY VOLTAGE	CAPACITY* (SEE BELOW)	ENVIRONMENT* (SEE BELOW)	LAMP DESIGNATOR	OPTIONS
<div style="border: 1px solid black; padding: 2px; width: fit-content; margin: 0 auto;">NF</div> <p>NF - NFORCER Series Industrial Emergency Unit with self-diagnostics</p>	<div style="border: 1px solid black; padding: 2px; width: fit-content; margin: 0 auto;"> </div> <p>6 - 6 volts DC 12 - 12 volts DC³ 24 - 24 volts DC¹</p>	<div style="border: 1px solid black; padding: 2px; width: fit-content; margin: 0 auto;"> </div> <p>25 - 25 watts 50 - 50 watts 75 - 75 watts 100 - 100 watts¹ 125 - 125 watts³ 150 - 150 watts³</p>	<div style="border: 1px solid black; padding: 2px; width: fit-content; margin: 0 auto;"> </div> <p>BLANK - Standard Unit (0°C to 40°C) C - Cold Ambient Conditions (-40°C to 40°C) H - High Ambient Conditions (0°C to 55°C) E - Extreme Ambient Conditions (-40°C to 55°C)</p>	<div style="border: 1px solid black; padding: 2px; width: fit-content; margin: 0 auto;"> </div> <p>BLANK - No Heads 6 volt PAR36 Sealed Beam Tungsten PA - 8 watt PB - 18 watt PC - 25 watt PD - 30 watt 12 volt PAR36 Sealed Beam Tungsten PE - 12 watt PF - 18 watt PG - 25 watt PH - 30 watt 24 volt PAR36 Sealed Beam Tungsten PO - 50 watt Halogen PK - 8 watt PL - 12 watt PM - 37 watt PN - 50 watt</p>	<div style="border: 1px solid black; padding: 2px; width: fit-content; margin: 0 auto;"> </div> <p>A - Ammeter ACF1 - 120v AC Input Fuse ACF2 - 277v AC Input Fuse ACP1 - 120v AC Disconnect Switch ACP2 - 277v AC Disconnect Switch BDS - Battery Disconnect Switch EX - Special Input Transformer² (specify voltage & frequency) T - Self-Testing Diagnostics (non-audible) TA - Audible Self-Testing Diagnostics TD - Time Delay V - Voltmeter</p>
<div style="border: 1px solid black; padding: 5px;"> <p>*CAPACITY & ENVIRONMENT SELECTION (All units are Wet Location listed)</p> <p>Standard Unit - 6v, 25w; 6v, 75w; 6v, 100w; 12v, 25w; 12v, 75w; 12v, 125w; 12v, 150w; 24v, 100w</p> <p>C - 12v, 100w; 12v, 125w; 12v, 150w</p> <p>H - 6v, 50w; 12v, 50w; 12v, 100w; 12v, 125w; 12v, 150w</p> <p>E - 6v, 50w; 12v, 50w; 12v, 100w; 12v, 125w; 12v, 150w</p> </div>					

NOTES:

¹ 24 volt systems only available in 100 watt configurations.
² Certain option combinations may impact UL listing. Consult factory.
³ 125 and 150 watt units available in 12v DC configurations only.

ACCESSORIES

NUMK - Universal Mounting kit (column, pole or I-beam)
SRT - Self-test Infra-Red Remote Tester

NForcER SERIES - Industrial Emergency Unit

SPECIFICATION DATA

ELECTRONICS

INPUT POWER REQUIREMENTS

6 Volt and 12 Volt, Standard and 'H' - High Ambient Units

120 VAC, 60 Hz = 0.319 A,
277 VAC, 60 Hz = 0.142 A

6 Volt and 12 Volt, 'C' - Cold Ambient and 'E' - Extreme Ambient Units

120 VAC, 60 Hz = 0.683 A,
277 VAC, 60 Hz = 0.305 A

24 Volt Models

120 VAC, 60 Hz = 0.507 A,
277 VAC, 60 Hz = 0.227 A

BATTERY

Maintenance-free, sealed nickel cadmium, lead calcium and pure lead batteries are pre-qualified based on anticipated ambient temperature exposure. All capacity ratings are based on the lowest extreme temperature rating of the fixture, producing a minimum of 90 minutes emergency operation without de-rating the unit.

SELF-DIAGNOSTICS

Standard circuitry is designed around an 8-bit microprocessor to provide unmatched reliability and performance.

Standard features include:

- Transformer isolated input
- Low-voltage disconnect (LVD)
- AC lockout (line latch)
- AC power indicator
- Brownout protection
- Charge status indicator
- Visual fault indicator
- Audible user interface control
- On-board IR receiver
- Precision temperature compensation
- Dual voltage 120/277 VAC, 60Hz input with surge protection is standard on all models.

The low voltage disconnect (LVD) feature will disconnect the battery prior to an unacceptable deep discharge, but not before the required 90 minute emergency operation.

The brownout protection circuitry will automatically switch the unit into the emergency mode if the utility voltage drops below 25% of nominal input voltage.

The AC lockout (line latch) feature prevents battery drain prior to the initial energizing of utility power, and allows the installer to complete all wiring and electrical connections without energizing the emergency circuit.

DIMENSIONS

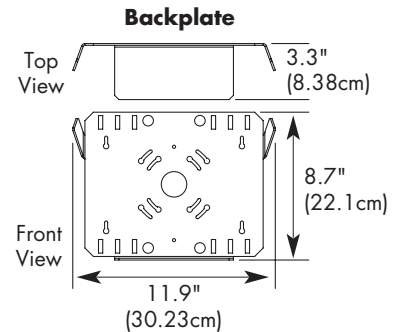
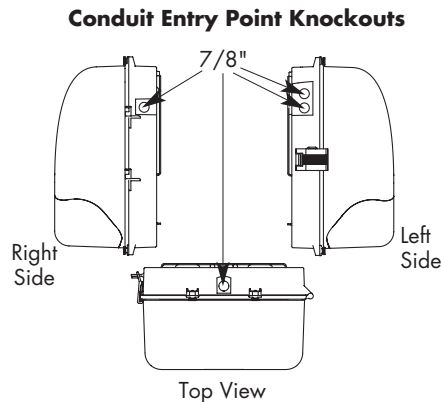
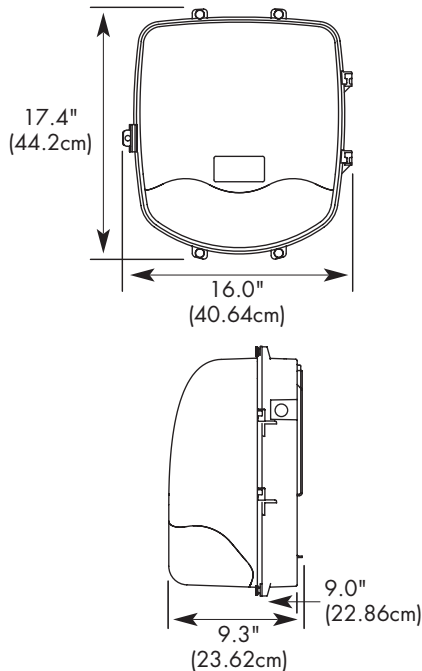

NForcER SERIES - Industrial Emergency Unit

SELF-DIAGNOSTICS & CIRCUITRY

SYSTEM OPERATION

The microprocessor has command of all critical circuit functions and operations including battery charging, emergency transfer, brownout detection, AC lockout/line latch, internal and remote load detection, temperature compensated charging as well as providing the outputs to signal trouble/faults.

Fault detection is always provided in a visual format with the option to have audible alarms as well. When audible diagnostics are used, the visual fault indicator (LED) and audible tone will be synchronized for clear fault identification. All faults except lamp failure are self healing. That is, when the microprocessor detects a corrected fault situation, the visual and audible fault modes are cleared and the fixture returns to the normal operating mode, excluding lamp failure (lamp failure is considered most critical and requires a transfer test to clear the fault after re-lamping). A silence alarm feature is also provided to provide adequate time to clear the fault without having the audible alarm active while performing maintenance. In this case, the visual indicator remains active. Should the fault not be restored after a period of one week, the audible tone returns to bring attention to repair personnel.

During prolonged periods without power (either during a power loss or shutdown due to vacancy), any alarm conditions and lamp load data are stored in the non-volatile memory. Upon restoration of power, a quick self-test, as part of the system initialization, will occur and the results will be compared to the stored data. Results of the self-test are compared to the stored data for proper indicating options.

CHARGER

The charger is a two-stage, constant-current charging system constantly monitored and under control from the microprocessor. The charging state is visually apparent by viewing the charge status indicator. A flashing green indicator indicates a high-charge mode while a steady green indicator indicates the battery is at full charge and subjected to a trickle charge as needed. Temperature compensation is always enabled by the thermal detection system on board the microprocessor and has an effective range from -40°C to 55°C. The temperature compensation algorithm is equal to 3mv/°C, providing ideal charging conditions.

CHARGER MONITOR CIRCUIT

The charger monitoring circuit constantly samples and compares the voltage and current being sent to the battery, during normal AC operation, against preset limits programmed in the microprocessor. Should the compared voltage or current remain out of limits for a period of five clock cycles, the microprocessor will command a charger fault alarm condition.

BATTERY MONITORING CIRCUIT

The battery voltage is continuously monitored during normal AC operation and compared to preset limits programmed in the microprocessor. During a manually invoked or automatic self-test routine, the battery voltage is monitored for proper capacity-to-load ratios and indicates a battery fault if it is determined the unit will not meet the 90-minute required run time. This circuit also monitors the system for a "Reverse Polarity" condition on the battery connection. A reverse polarity condition will result in a microprocessor command to shut down normal operations and indicate a battery failure, thus preventing any damage to the circuitry.

LAMP LOAD MONITORING

The lamp load voltage and current are continuously monitored and compared to preset limits stored in the microprocessor. The resolution of the monitoring circuit exceeds the UL required 10% detection rate for emergency lighting fixtures. Should the compared voltage or current remain out of limits for a period of five clock cycles, the microprocessor will command a lamp failure alarm condition. If lamp loads are changed any time after installation and application of power, a user-invoked load calibration may be performed.

TRANSFER CIRCUIT MONITORING

The transfer circuit is monitored any time the unit is cycled into a manual or automatic test. Any noted deficiency in the transfer of the equipment to the emergency mode will display a transfer fault condition.

OVER/UNDER VOLTAGE MONITORING

During system initialization, the microprocessor will sample and verify the utility voltage against preset limits stored in the memory. If after five clock cycles the voltage does not fall within the pre-determined parameters, the unit will not complete initialization and will toggle the red (fault) and green (AC on, charge status indicator) in the following manner:

Both RED and GREEN LED's fast toggle with audible tone -

AC line over-voltage

Both RED and GREEN LED's slow toggle - AC line under-voltage

OPTIONAL SELF-TESTING

The self-testing routine, if enabled, is a function of the internal microprocessor clock and the code generated sequence timer. Every thirty days, the program commands the microprocessor to perform a self-test by transferring the unit to the emergency mode for a period of one minute with the exception of the sixth and twelfth month. On the sixth and twelfth month, the self-test duration is extended to 30 minutes to exercise the battery.

The circuitry is also equipped with a manual test inhibitor. While the equipment is in a high charge state due to prolonged power outage or extended on-site testing equivalent to 10 minutes discharge time, the 90-minute manual test mode shall be inhibited to allow the unit to recover properly for life safety purposes. During this time, the user may initiate a one-minute test to verify proper operation of the equipment.

AUDIBLE/NON-AUDIBLE DIAGNOSTICS

Circuit is equipped with an audible user interface confirmation standard. However, the audible diagnostics feature is a selectable option. Standard diagnostics equipment offers visual verification of the equipment readiness through the flashing sequence of the RED LED in the following manner:

Fault condition status, number of RED flashes:

1 X - Battery Fault

2 X - Lamp Failure

3 X - Charger Fault

4 X - Transfer Fault

Both RED and GREEN LED's fast toggle with audible tone -

AC line over-voltage

Both RED and GREEN LED's slow toggle - AC line under-voltage

NForcER SERIES - Industrial Emergency Unit

SPECIFICATION DATA

AVAILABLE ACCESSORY ITEM

SRT Self-Test Infra-Red Remote Tester

Indoor range: 30-40 ft.

Outdoor range: varies depending on exposure to sun

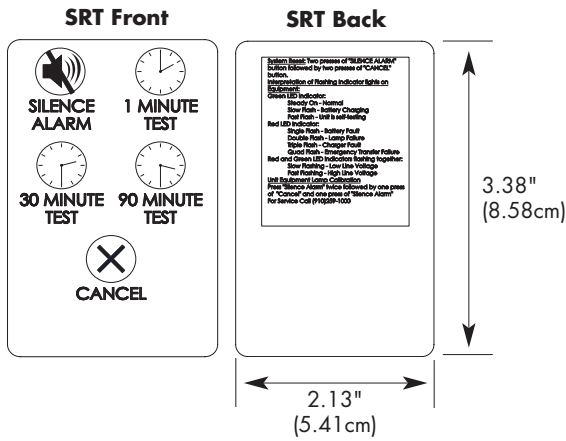

Note: In outdoor applications, the IR test device may be limited to short distances due to exposure to the sun.